

UNPAVED TEMPORARY  
N.T.S.

4.0% SLOPE FROM CENTER OF BULB TO LIP OF GUTTER ALONG C PROFILE ONLY

TYPE I CURB/GUTTER

INSTALL CRACK CONTROL JOINTS 5' O.C.

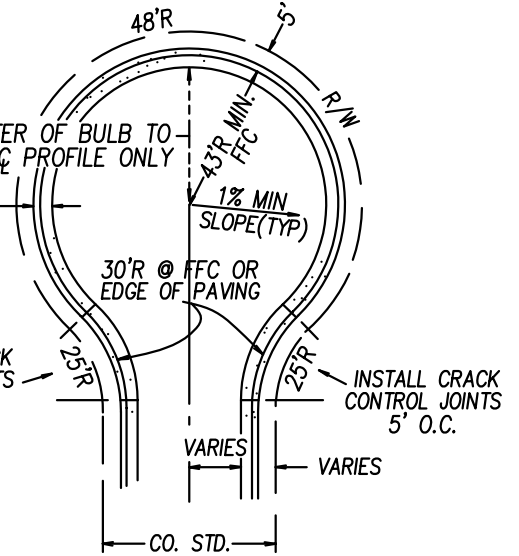

PAVED PERMANENT  
N.T.S.

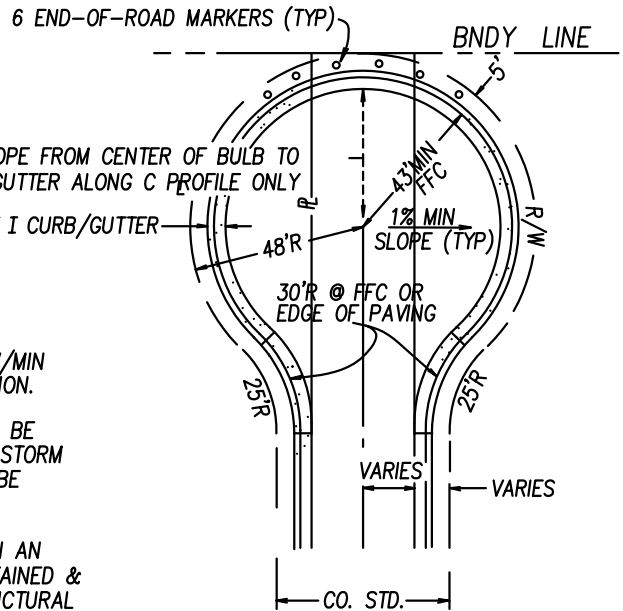

PAVED TEMPORARY  
N.T.S.

NOTES

1. TEMP TURNAROUND EASEMENT DOCUMENT REQ'D W/MIN 48' RADIUS TO BE ABANDONED W/STREET EXTENSION.
2. DRAINAGE OF UNPAVED TEMP CUL-DE-SAC SHALL BE CONSISTANT W/CO. STDS INCLUDING ARTICLE 420 STORM DRAINAGE & TO BE USED ONLY IF STREET IS TO BE EXTENDED WITHIN 1 YR.
3. PAVED TEMP TURNAROUND SHALL BE CONST WHEN AN OFF-SITE TEMP TURNAROUND EASE CAN'T BE OBTAINED & STREET IS TO BE EXTENDED IN THE FUTURE. STRUCTURAL SEC. OF TURNAROUND TO MATCH STREET SEC., REFER TO CODE 111.444 FOR CONSTRUCTION.
4. PAVED TEMPORARY TURNAROUND IS REQUIRED ON ALL FUTURE THROUGH-STREETS THAT FRONT LOTS, OR EXTEND MORE THAN 150 FT BEYOND THE NEAREST INTERSECTING STREET.

STANDARD DETAILS FOR PUBLIC WORKS CONSTRUCTION				SECTION: WASHOE	
NO.	REVISED	DATE	<b>CUL-DE-SAC</b>	DRAWING NO: W-7	
1	REDRAWN	5/94 vp		DATE: 5/94 vp PAGE: 18	
2	4%-NOTE 4	10/96 vp			
3	RADII	9/97 vp			
4	Profile note	5/99vp			