

SECTION 110.436.25-2: ROADWAY SECTIONS - B

GENERAL APPLICATIONS: URBAN AREAS, SUBURBAN AREAS, LOT SIZES LESS THAN 0.5 AC.

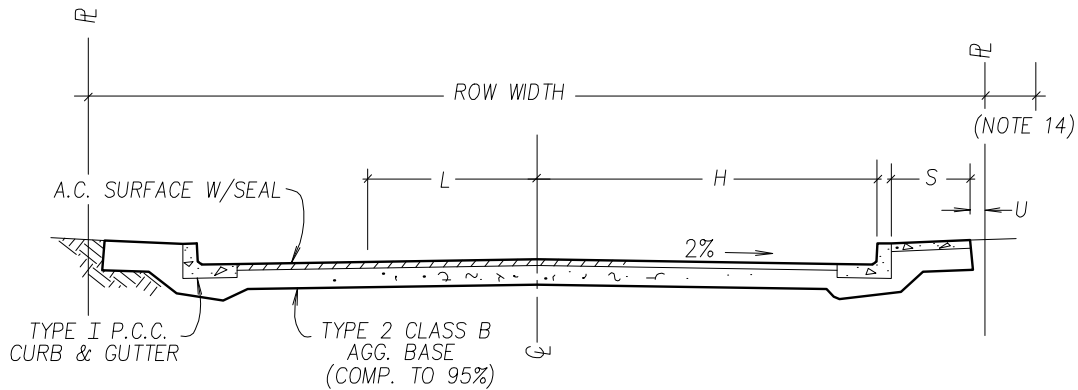

ROW	H	S	U	L	B	PL	ADT MAX PER 2 TRAVEL LANES	REMARKS
52	20	5	0.5	12	4	0	7300	COLLECTOR
42	16	4	0.5	11	0	2	1000	LOCAL

NOTES

1. ALL WIDTHS ARE IN FEET.
2. H IS MEASURED TO THE FRONT FACE OF CURB.
3. L IS TRAVEL LANE; S IS SIDEWALK; B IS BICYCLE LANE; PL IS MAX. NUMBER OF PARKING LANES ALLOWED; ROW IS RIGHT OF WAY; ADT IS AVERAGE DAILY TRAFFIC.
4. ADT REPRESENTS THE DESIGN VOLUME FOR A TWO LANE FACILITY.
5. BICYCLE LANE SHALL BE PROVIDED IN ACCORDANCE W/THE BICYCLE AND PEDESTRIAN ELEMENT OF THE REGIONAL TRANSPORTATION PLAN AND TO THE SATISFACTION OF THE COUNTY ENGINEER.
6. STRUCTURAL SECTIONS SHALL BE DETERMINED BY GEOTECHNICAL ENGINEERING DESIGN BUT IN NO CASE SHALL BE LESS THAN 4" A.C. OVER 6" GRAVEL BASE FOR COLLECTOR STREETS AND 3" A.C. OVER 6" GRAVEL BASE FOR LOCAL STREETS.
7. ALL CURB AND GUTTER IS MONOLITHIC CONC. AND L SHAPED PER STANDARD DETAIL.
8. SIDEWALK AREA IS CONC. BOTH SIDES FOR COLLECTORS, ONE SIDE FOR LOCALS. ALTERNATE SIDEWALK LOCATIONS/CONFIGURATIONS MUST BE APPROVED BY THE COUNTY ENGINEER.
9. ALL A.C. SURFACES SHALL BE SEALED IN ACCORDANCE WITH WASHOE CO. STANDARDS.
10. RESIDENTIAL DRIVEWAY ACCESS NOT ALLOWED TO STREETS ON WHICH 10YR. DESIGN ADT EXCEEDS 2000.
11. DESIGN OF IMPROVEMENTS TO BE DONE IN ACCORDANCE WITH ARTICLES 420 & 436 OF WASHOE COUNTY DEVELOPMENT STANDARDS AND DESIGN GUIDELINES.
12. ALL CONSTRUCTION IS TO BE DONE TO CURRENT WASHOE CO. STANDARDS & SPECIFICATIONS.
13. SLOPE EASEMENTS MAY BE REQ'D IN CERTAIN TERRAIN TO ACCOMMODATE THE ROADWAY SECTION.
14. MIN 7.5' PUBLIC UTILITY/TRAFFIC CONTROL SIGNAGE/PLOWED SNOW EASEMENT IS REQ'D ON BOTH SIDES OF ROW.

NO.	REVISED	DATE	STANDARD DETAILS FOR PUBLIC WORKS CONSTRUCTION			SECTION:
6	changed adt	12/05sw	ROADWAY SECTIONS GENERAL APPLICATIONS URBAN AREAS/SUBURBAN AREAS LOT SIZE: LESS THAN 0.5 ACRE	B	WASHOE	
3	Sub/Notes	1/94vp			DRAWING NO: W-1.2	
4	Corr "U"	2/94/vp			DATE: 2/93vp PAGE: 2	
5	Save As W-2.dwg	10/01vp				