

MANHOLE COLLAR
Not to Scale

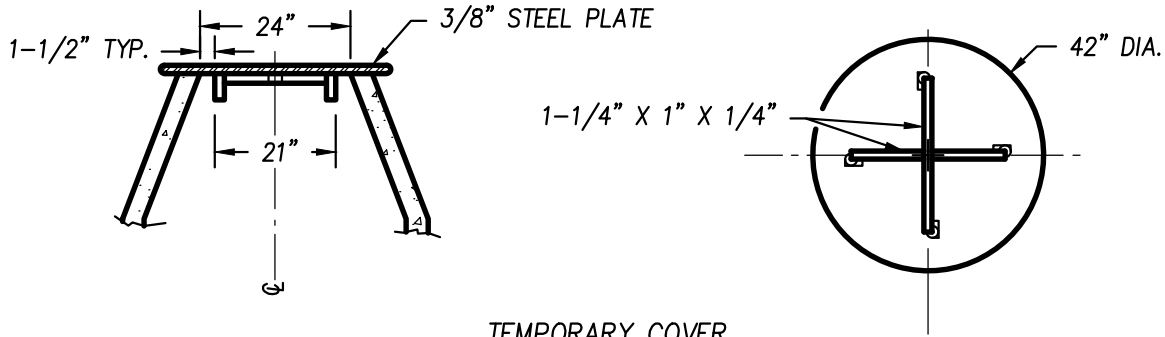

TEMPORARY COVER
Not to Scale

NOTES:

1. CONCRETE COLLAR TO BE PORTLAND CEMENT CONCRETE (PCC) SHALL HAVE THE FOLLOWING CHARACTERISTICS: 4000PSI MIN. COMP STRENGTH @ 28 DAYS, MIN. 6 SACKS OF CEMENT PER CU.YD. WITH MAX WATER-CEMENT RATIO OF 0.45, AIR ENTRAINMENT 6% ± 1.5%, SLUMP @ 1 TO 4 INCHES. ALL MATERIAL SHALL CONFORM TO SSPWC SEC. 202.
2. HEIGHT OF COLLAR SHALL BE CONSISTENT ALL AROUND MANHOLE.
3. MANHOLE RIM SHALL BE SET 3/8"-5/8" BELOW FINISH ROADWAY SURFACE. MANHOLES IN GRAVEL ACCESS ROADS SHALL BE SET FLUSH W/FINISH GRADE UNLESS OTHERWISE NOTED. MANHOLES IN UNIMPROVED AREAS SHALL BE SET 12"-18" ABOVE FINISHED GROUND.
4. CONCRETE COLLAR SHALL BE LEFT 2"-4" BELOW FINISH ASPHALT SURFACE. PLACE TYPE 3 A.C. PAVING AROUND MANHOLES TO MATCH ADJACENT PAVEMENT & APPLY SS-1 TACK COAT BEFORE PAVING, SEAL A.C. SURFACE W/SS-1 & SAND CHIP SEAL, SLURRY SEAL, SAND SEAL OR FOG SEAL PAVED SURFACE AS REQ'D BY PLANS OR SPECS. EXCEPTION - EXTEND CONC COLLAR TO FIN. GRADE WHEN NOT LOCATED IN ASPH PAVE OR IN AN UNPAVED AREA.
5. STEPS ARE REQ'D FOR SANITARY SEWER/STORM DRAIN MANHOLES OF 5 FEET OR GREATER DEPTH FROM FINISHED GRADE TO FLOW LINE.
6. MANHOLES THAT INDICATE AN ELEVATED FINISHED LID SHALL EITHER HAVE A CONCRETE COLLAR AS SHOWN ABOVE OR SHALL BOLT THE RIM AND GRADE RINGS TO THE CONE SECTION.
7. MANHOLE COVER TO CLEARLY STATE "WASHOE COUNTY SEWER"
8. MANHOLE COLLARS INSTALLED IN THE CITY OF RENO OR SPARKS ROADWAYS SHALL BE BROUGHT TO GRADE ACCORDING TO THE RESPECTIVE REGULATIONS.

NO.	REVISED	DATE	STANDARD DETAILS FOR PUBLIC WORKS CONSTRUCTION	SECTION:	WASHOE
			MANHOLE COLLAR	DRAWING NO:	WR-1.8
				DATE: 7/09	PAGE: 8